



PARROT

PAR 4-20 SYSTEM SETUP



PARROT MODULES

The Parrot International range of products are designed to fit on a standard DIN rail. Please take care when clipping modules to rails. Always ensure that there is access to the terminals that are to be used taking into account the bend radius of the wire to be used. Please advise frequency to be used.

The system is designed so that As an option and in order to ensure the integrity of the system in the event of a loss of transmission or power a normally energized relay on the Rx will operate giving a fault relay output. Please state if you require relay 4 configured as a fault relay at time of order.

The modules are shipped pre-paired and the transmission time is normally set to one minute. This is presettable at the factory. The optional fault relay will operate if the Rx unit does not receive a check signal in 2.5 times the transmission check time. For example if the transmission time is 60 seconds, if there is a loss or power at the TX or it fails to transmit then after 150 seconds the fault relay will operate. Please state your required transmission time at time of order.

PAR MODULES SIZE

The Parrot modules have the overall following dimensions

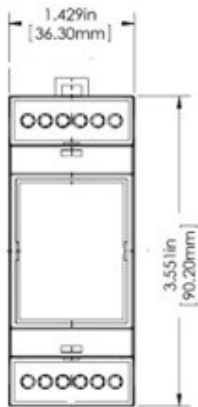

PAR 4-20 WIRING

The Parrot PAR 4-20 is a 4-20mA input module paired with a 4-20mA output module.

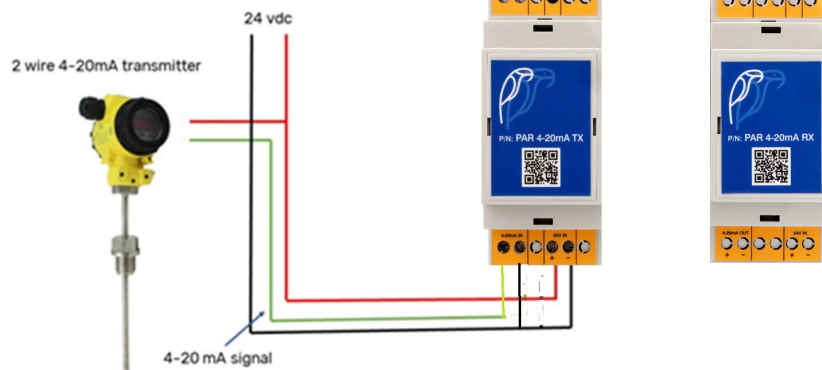

SET UP AND OPERATION

The Parrot International range of products communicate using radios. Before installation please ensure you have radio communications between the Transmitter and Receiver. This can be determined by using the PAR survey kit.

The modules are pre-paired and do not require to be paired on site. As the modules are connected by radio it is recommended that they be commissioned as pairs using the following procedure. Do not turn on ALL modules at one time. The units that are paired are marked as a pair by the serial number on the right hand side of each module.

When the Tx and RX units are installed on the DIN rail in their respective locations apply power to both. The units will initially show an orange LED to indicate "power on" which is visible through the 24vdc terminal holes, and white LED which is visible on the top right of the terminal strip along side the "switch" for about 3 seconds. The power LED remains lit as long as power is applied.

On either the Tx or Rx unit Insert a "trimpot adjuster" screwdriver, or similar, through the top right hand terminal hole and press the "switch". The LED will light green, to indicate the unit is either transmitting or receiving. The green LED on the corresponding Tx or Rx will also light. If the transmission check time is 60 seconds the green LEDs on both the Tx and Rx will light for about 6 seconds in every 60.

Connect the 4-20 output on the Rx unit to the device that you wish to use. Connect a 4-20mA generator to the input of the Tx unit and inject a signal of 6mA. Press the "switch" and the mA level will be transmitted to the Rx and indicated on the device you have chosen. We suggest you repeat for 12mA and 18mA. If the optional fault relay has been requested, we suggest you disconnect the 4-20 generator and the fault relay will operate after 150 seconds.

The system is now in operation. On receipt of an input on the transmitter a corresponding output on the receiver will operate. Repeat this set up for all pairs on the system.

In the event of a loss of transmission the green LED will be red when the next assigned transmission check is initiated. This will automatically revert to green when communications are re-established. It is possible to manually check communications by operating the switch on either the Tx or Rx with the trimpot or instrument screwdriver.